

ACURO – SSI / BiSS



General	2
Electrical Data	2
General Design	2
Supply Voltage (SELV)	2
Intrinsic current consumption (w/o output current)	2
Resolution and Accuracy	2
Incremental Signals A, B	3
SSI	4
Electrical Data	4
Physical interface	4
Data format:	4
Pinout PCB – Connector 12pin	5
SSI - Protocol	6
Protocol standard SSI	6
Protocol SSI Extended	8
High resolution SSI and SSI extended (resolutions > 14 Bit)	9
Timing SSI	10
BiSS	11
Electrical Data	11
Input / Output Signal	11
Outputs:	11
BiSS Protocol	11
Bidirectional Serial Sensor Interface (BiSS)	11
Transmitting sensor data (BiSS-Mode)	12
Register – mode (BiSS – Interface)	13
Register mode: read	14
Register mode: write	14
Timing	15
Timing BiSS Sensor Mode	15
Timing BiSS Register Mode	16
Example for read register 78h	17
Hints for PWM Signals	18
CRC - Generation	19
Address MAP	22
Register Map	23
Recommended Interface	25
SSI Standard with Incremental signals	25
BiSS Standard Encoder	26
Electrical behaviour at power up in BiSS Mode	27

1 General

General information, applications

The "Acuro - Industry" optical absolute encoder is available as a singleturn or multiturn version. The multiturn design is based on a reliable high-speed gear with optical scanning and the latest generation of OptoAsics. The mechanical concept is based on a double ball bearing design, which is available as a solid-shaft or hollow-shaft version in common diameter sizes. The field of application encompasses positioning tasks in all industrial applications.

The electrical concept of the Acuro series is addressing the ever progressing requirements of industrial applications and the state of the art in interface technology. Additional to the widespread absolute encoder interface SSI, the Acuro series features the open and bidirectional high speed sensor interface **BiSS**. The physical layer of the BiSS interface is backward compatible to SSI. To match with the still often used sine wave analog inputs in motion control applications the Acuro is available also with sine wave output combined with SSI.

Electrical Data

General Design

Protection Degree III
Pollution Degree 2
Over voltage Category II

according DIN EN 61010 part 1 (03.94)/ EN 61010-1/A2 (05.96) (VDE 0411)

Supply Voltage (SELV)

DC 5 V –5%/ +10%
DC 7...30 V

Intrinsic current consumption (w/o output current)

Singleturn: at DC 5 V ≤ 45 mA
Multiturn: at DC 5 V ≤ 85 mA

Resolution and Accuracy

Incremental Signals (A, B)
2048 Periods / Revolution

Revision	©Hengstler GmbH Postfach 1151 78550 Aldingen	Page
3 050517TK	☎ 07424/89-0 Fax 07424/89-500 email: info@hengstler.com Internet: www.hengstler.com	2 / 29

ACURO – SSI / BiSS

Incremental Signals A, B

Track A leads B by 90° at rotation and view on shaft end.

$$A = U_M + \hat{u}_A \sin(z\varphi_{\text{mech.}})$$

$$A^* = U_M - \hat{u}_A \sin(z\varphi_{\text{mech.}})$$

$$B = U_M - \hat{u}_B \cos(z\varphi_{\text{mech.}})$$

$$B^* = U_M + \hat{u}_B \cos(z\varphi_{\text{mech.}})$$

z: No. Of signal periods (2048)

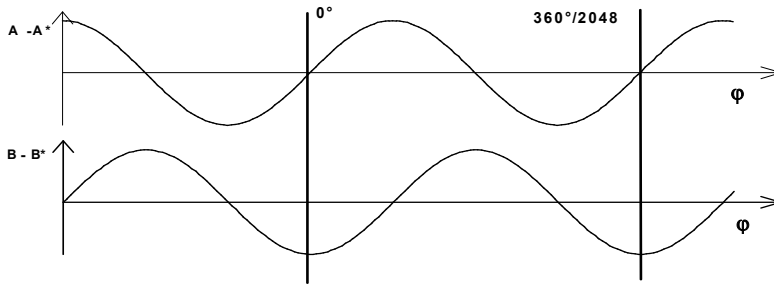

Amplitudes:^{1) 2)}

$$\hat{u}_{(A-A^*; B-B^*)} = 0,5V - 25\% / + 20\%$$

$$\hat{u}_{(A-A^*; B-B^*)} = 0,35V \dots 0,6V$$

$$f_{gr} = 500 \text{ kHz}$$

$$\hat{u}_{(A-A^*)} = \hat{u}_{(B-B^*)} \pm 10\%$$

$$m \leq 0,1$$

$$|U_{\text{off}}(A-A^*; B-B^*)| < 0,1 \hat{u}_{(A,A^*; B,B^*)}$$

$$\varphi = 90^\circ \pm 3^\circ$$

$$k < 2\% \text{ (typ. } 1\%)$$

$$U_M = 2,5V \pm 20\%$$

• Signal
(f ≤ 1kHz)
(f > 1kHz)

• Limiting frequency

• Amplitudes difference ¹⁾

• Degree of modulation (mech.) ⁴⁾

• Offset

• Phase A to B ⁶⁾

• Harmonic distortion ³⁾

• DC Offset ⁵⁾

¹⁾ : measured with 120 Ω termination resistor at encoder output

²⁾ : at f = 1 kHz (corresponds to 30 U/min)

$$^3) k = \frac{\sqrt{U_1^2 + U_2^2 + \dots + U_n^2}}{\sqrt{U_0^2 + U_1^2 + \dots + U_n^2}}$$

U0: Basic Signal , U1 ... Un : harmonics

$$^4) m = \frac{\Delta u}{u}$$

⁵⁾ U_M same for A and A* and for B and B* signals.

⁶⁾ Average

BiSS	Technical Datasheet Interface	HENGSTLER
ACURO – SSI / BiSS		

SSI

Electrical Data

Physical interface

Number of wires 4 unidirectional

Data and /Data:	RS485-Level
Clock and /Clock:	RS485-Level
Driver Output current:	max.60 mA
Short circuit output current:	<input type="checkbox"/> 250 mA

Transmission speed 70 kHz –1 MHz according to SSI definition

Data format:

The data alignment is MSB left flush. That means with the first rising edge the MSB bit is on the output. The output is programmable for binary or gray code.

Resolution standard SSI (25 data bits)

Data format MSB - left- flush	
Singleturn	13 Bit
Multiturn	12 Bit
Binary Code	

Optional: Resolution SSI with extendable data length (> 25 data bits)

Singleturn	max 19 Bit
Multiturn	12 Bit
*Singleturn in 25-Bit MT-Model	programmable up to 19 Bit

Monoflop – timeout $10 < t_m < 30\mu s$

Revision	©Hengstler GmbH Postfach 1151 78550 Aldingen	Page
3 050517TK	☎ 07424/89-0 Fax 07424/89-500 email: info@hengstler.com Internet: www.hengstler.com	4 / 29

Cable

For clock and data should be twisted in pairs and shielded

Baud rate / Cable length

cable length	Baud rate
< 25 m	< 1 MHz
< 50 m	< 400 kHz
< 100 m	< 300 kHz
< 200 m	< 200 kHz
< 400 m	< 100 kHz

Pinout PCB – Connector 12pin

	┌──────────┐					
Row b	5 or 7-30 V (UB) gr/pk	Clock wt	B- rd	0V (UN) wt/gn	A- ye	Data bk
Row a	Data/ vio	A+ gn	0V Sens bn/gn	B+ bl	Clock/ bn	5 V Sens rd/bl
PIN	1	2	3	4	5	6

Hint:
 5 V (UB) → 5 V Sens
 0 V (UN) → 0 V Sens

Connection on encoder side over
 12-pin PCB connector,
 Manufacturer Berg, Type: Minitek.

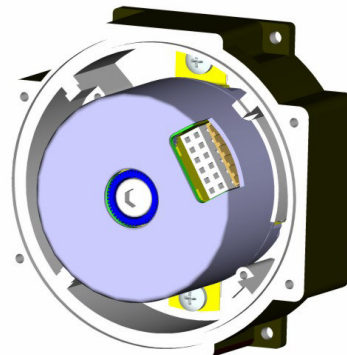

SSI - Protocol

Protocol standard SSI

The SSI data transmission of an absolute encoder position value is based on a shift register, where the shift clock is provided by the external control. The encoder provides its position data and depending on configuration also status information synchronous to the external clock on the data line. Both lines are physically according to RS422 specification.

Clock pulse diagram

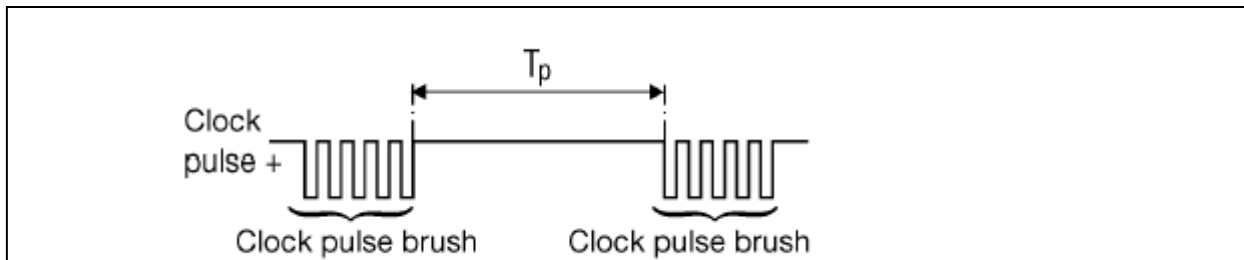

Transmission Cycle

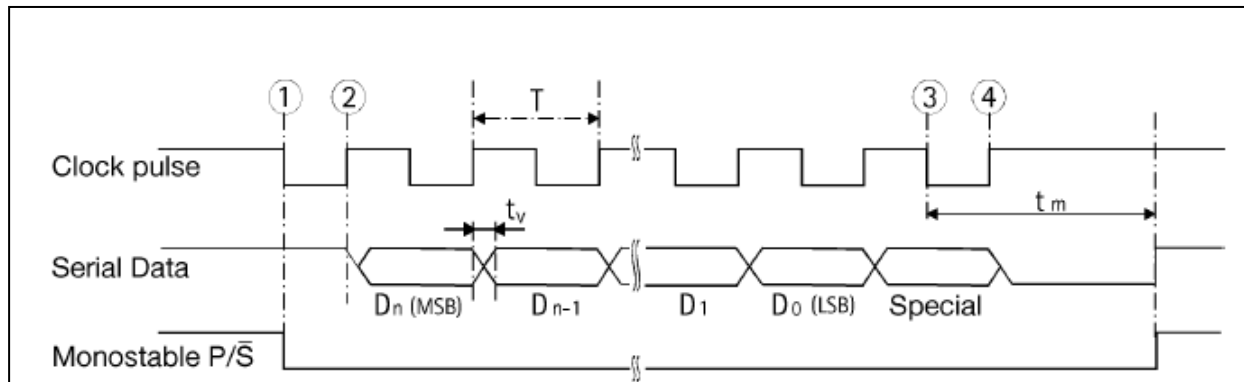

For correct transfer of the data a defined number of impulses (clock pulse brush) must be applied to the clock input of the absolute shaft encoder. Next, a pause T_p must be observed. As soon as a clock pulse brush is applied to the clock pulse input, the actual angle information will be latched.

With the first shift of the clock signal from low to high ② the most significant bit (MSB) of the angular data is applied to the shaft encoder's serial output. With each succeeding rising edge, the next less significant bit is shifted to the data output. After transmission of the least significant bit (LSB) the Alarm bit or other special bits are transferred, depending on configuration. Then the data line switches to low ③ until the time t_m has passed. A further transfer of data cannot be started until the data line switches to high ④ again. If the clock pulse sequence is not interrupted at point ③, the ring-register mode is activated automatically. This means that the data stored at the first clock pulse transition ① are returned to the serial input S_i via the terminal S_O . As long as the clock pulse is not interrupted at ③, the data can be read out as often as wanted (multiple transfer). The number of clock pulses necessary for data transfer is independent of the resolution of the absolute shaft encoder. The clock signal can be interrupted at any point, or continued in ring-register mode for repeated polling.

Revision	©Hengstler GmbH Postfach 1151 78550 Aldingen	Page
3 050517TK	☎ 07424/89-0 Fax 07424/89-500 email: info@hengstler.com Internet: www.hengstler.com	6 / 29

ACURO – SSI / BiSS

With a data length of 25 Bit (simple transmission) the transmission after the lowest Bit (LSB), the data line holds on low, till the time t_m is elapsed.

Clock frequency: 100 kHz ... 1,5 MHz
 Monoflop time t_m : $12 \mu s = t_m = 20 \mu s$
 Clock pulse brush: 25 Clock cycles for Multiturn
 13 Clock cycles for Singeltturn

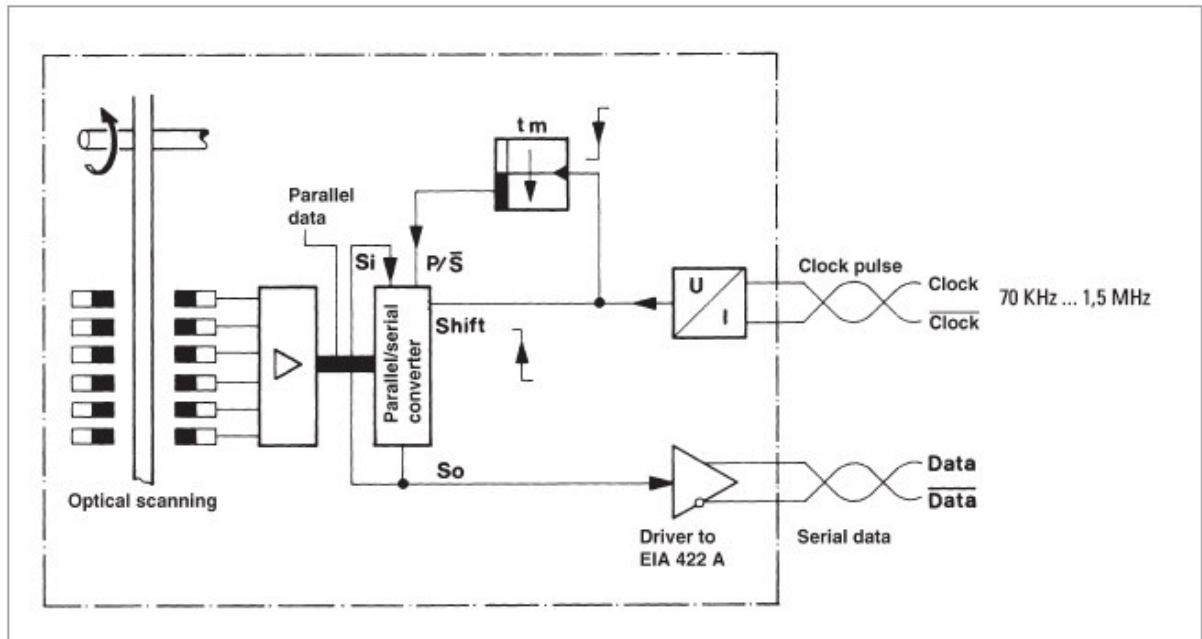

ACURO – SSI / BiSS**Protocol SSI Extended****SSI interface: extended SSI formats**

In extended SSI mode singleturn data of up to 21 bits and an additional 12 to 24 bits of multiturn data can be transmitted. This is followed by the 8-bit temperature value.

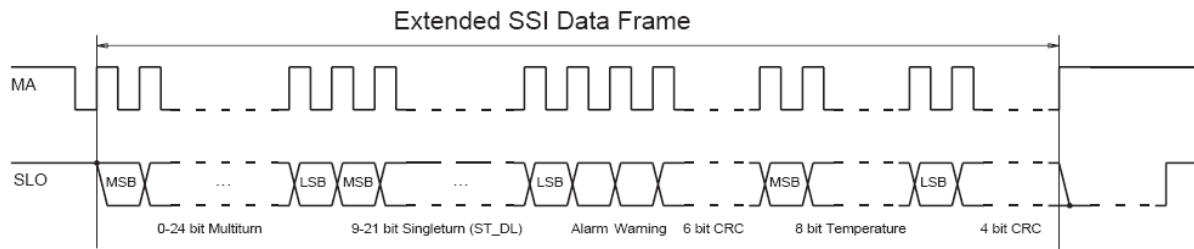
**Expansions compared to SSI standard format:**

After the position data there are two additional bits that indicate the status of the encoder. First the alarm bit and then the warning bit.

The reports from the LED current control or the temperature control can be assigned freely between the two bits (alarm, warning).

In the standard version the alarm bit is assigned to the LED current control and the warning bit is assigned to the internal temperature sensor.

Function: If one of the fault conditions occurs, the alarm bit is set "high" (,1'bit in the protocol). After reading a new position value the alarm bit is cleared automatically again. If the cause for the alarm is not longer present, the alarm bit is set to '0' (in the protocol is like '0'). Should the cause still be present, the alarm bit is set once more ('1').

6 Bit CRC Checksum

To guarantee a safe data transmission, there is a 6 bit CRC checksum over data and status bits. The start value of the checksum is 43h (1000011b). The checksum is formed and transferred in inverted format. First of the 6 Bit CRC transmitted is CRC5 CRC0.

Temperature

A temperature sensor with a resolution of 1 °C (LSB) within a range of -64 °C to +191 °C has been included on the internal OptoAsic chip for the monitoring of the operating temperature. The current temperature is stored as an 8-bit value. The sensor is calibrated in such a way that the value "0100 0000" is produced at 0 °C. The sensor sets error bit when either the upper or lower alarm thresholds have been exceeded.

Example temperature value = 59h (59h – 40h = 19h) temperature 25° C

4 Bit CRC Checksum

To guarantee a safe temperature transmission, there is a 4 bit CRC checksum

The start value of the checksum is 13h (10011b). The checksum is formed and transferred inverted format. First of the 4 Bit CRC transmitted is CRC3 CRC0.

Revision	©Hengstler GmbH Postfach 1151 78550 Aldingen	Page
3 050517TK	☎ 07424/89-0 Fax 07424/89-500 email: info@hengstler.com Internet: www.hengstler.com	8 / 29

ACURO – SSI / BiSS

High resolution SSI and SSI extended (resolutions > 14 Bit)

For Singleturn resolutions > 14 Bit either the Clock frequency must not exceed 100 kHz, or with higher clock frequencies the first negative Clock pulse needs to be on low level for minimum t_{SAR} time. This is due to the time needed for internal A/D conversion.

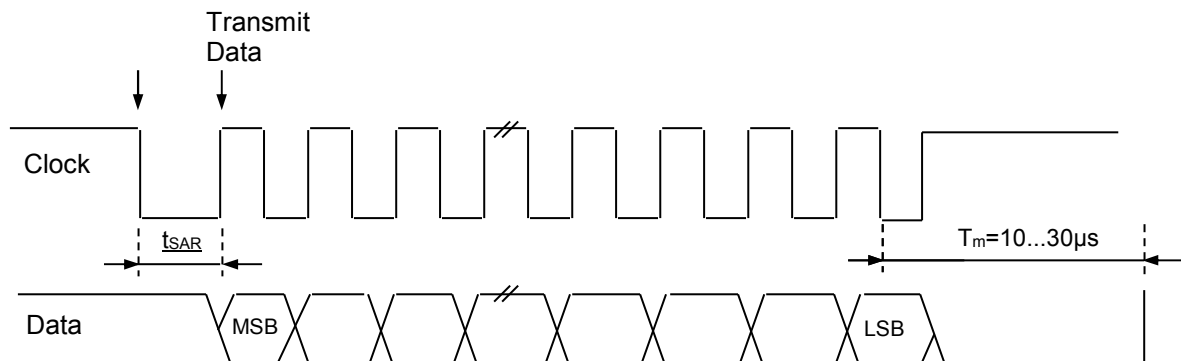

*need only for Singleturn resolutions > 14 Bit

Example how to calculate t_{SAR} : The resolution of the encoder shall be 1217, so the single turn part is 17 bit. The 17 bit consists internally of 11 bit digital information and 6 bit interpolated information. So we need time for 6 bits interpolation. If n is the number of interpolation bits we need (worst case) $600 * (n+1)$ ns calculation time. Now you can calculate the delay: it is $(6bit + 1) * 600ns = 4,2 \mu s$. After this time the output value is ready to be transmitted.

Revision	©Hengstler GmbH Postfach 1151 78550 Aldingen	Page
3 050517TK	☎ 07424/89-0 Fax 07424/89-500 email: info@hengstler.com Internet: www.hengstler.com	9 / 29

ACURO – SSI / BiSS

Timing SSI

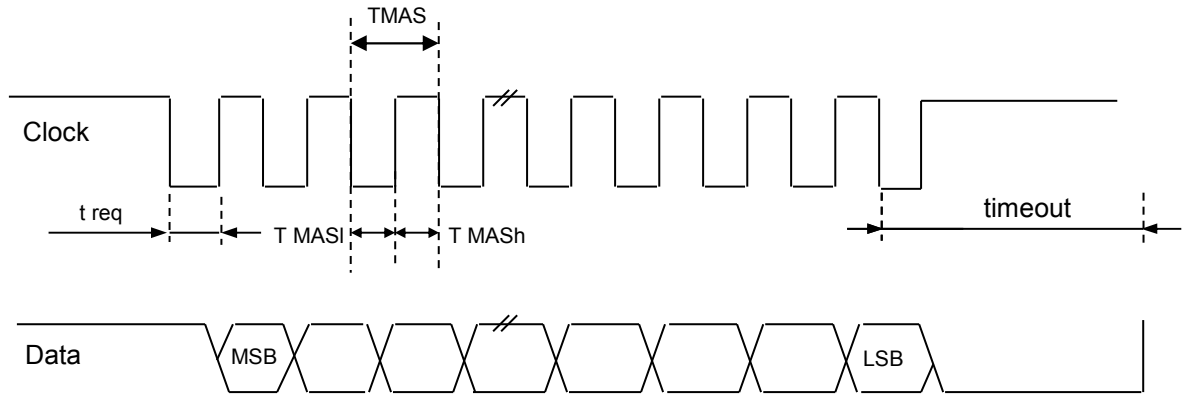

*needed only for Singleturn resolutions > 14 Bit

SSI Mode						
Symbol	Parameter	Conditions	min	typ.	max.	Unit
timeout sens (Ttos)*			9,9	12,4	14,9	μ s
TMAS	Permissible Clock Period		250 ns		$2 \cdot Ttos$	
tMASH	Clock Signal Hi Level Duration		125		Ttos	ns
tMASl	Clock Signal Lo Level Duration		125		Ttos	ns
treq	Data Request Lo Level Duration	only with SAR converter	t_{SAR}		Ttos	ns
fclk	Clock Frequency		4	5	6	MHz
tSAR	Conversion Time SAR Converter	n = resolution of SAR converter		$2(n+1)/fclk$		μ S

* Ttos = is programmable Time

BiSS	Technical Datasheet Interface	HENGSTLER
ACURO – SSI / BiSS		

BiSS

Electrical Data

Input / Output Signal

Clock and /Clock:	RS485 (Input)
Data and /Data:	RS485 (Output)
Clock frequency:	100 kHz ...10 MHz (13 Bit or more: clock frequency max. 9,1MHz)
Timeout _{SENS} *:	12µs
Timeout _{reg.} *:	51µs
* Timeout _{SENS} and timeout _{reg} are programmable	

Outputs:

Driver output current:	max.60 mA
Short circuit output current:	± 250 mA

Cable

Leads for clock and data should be twisted in pairs
 Entire cable shielded and according to CAT 5
 Cable capacity ≤ 100 pF/m
 Cable length max 100 m
 Baud rate < 10 MHz

BiSS Protocol

Bidirectional Serial Sensor Interface (*BiSS*)

The Serial BiSS communication differentiates between the fast transmission of sensor data and the slower transmission of register data. The transmission of sensor data is unidirectional; here, ACURO can only output data, whereas the bidirectional transmission of register data can include read and write access.

The BiSS sensor interface can be operated in an SSI compatible mode, in which only a lower transmission speed is possible and ACURO may not demand processing time for procedures such as interpolation, for example.

Revision	©Hengstler GmbH Postfach 1151 78550 Aldingen	Page
3 050517TK	☎ 07424/89-0 Fax 07424/89-500 email: info@hengstler.com Internet: www.hengstler.com	11 / 29

Transmitting sensor data (BiSS-Mode)

Transmission is initiated by a falling edge on the master line (MA). The master then again ramps the master line up to high within a stipulated period (<timeout_{SENS}) and continues the clock pulse. ACURO acknowledges the request for sensor data on the second rising MA edge with a low signal at SLO (see description of the BiSS protocol). The next rising edge gives the validity of the position data and is interpreted as a start bit by the master.

Depending on the configuration the length of ACURO's position data varies between 9 and 45 bits, plus an error bit and a warning bit. With a maximum length of 47 bits this data is protected by a 6-bit cyclic redundancy check value or CRC (polynomial 0x43 = "1000011b") which directly follows the data. **MCD: Multicycle data is not supported!**

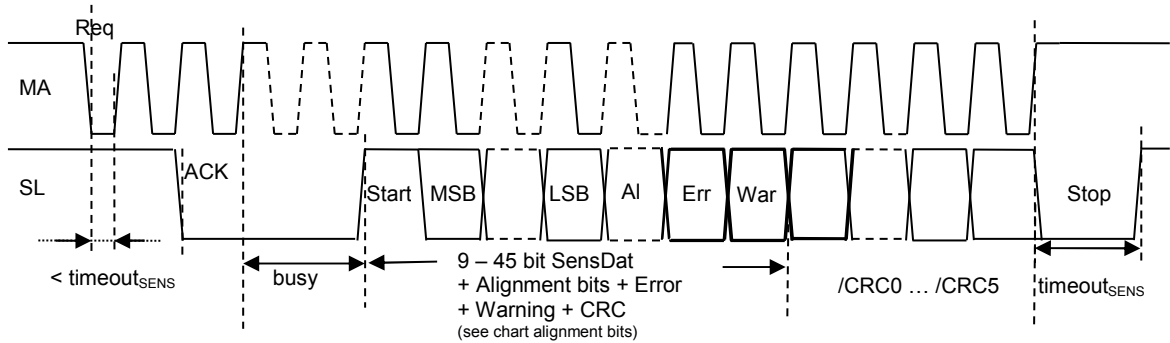

Transmission of sensor data in BiSS mode.

The Warning – Bit (War) is coupled to the internal temperature sensor of the OptoAsic. It is high, when the following temperature limits are exceeded or under - run:

Series	Operating temperature	Internal Warning thresholds
ACURO Industry (AC)	- 40° ... +100°C	-45° .. +105°C
ACURO Drive (AD)	- 15° ... +120°C	-20° .. +125°C

The Error – Bit (Err) is coupled to the LED – current. It is high, when an factory defined threshold is exceeded. An excess LED current can indicate Pollution; Condensation, Over temperature or Ageing of the LED

Chart: Alignment Bits

MT	ST	Alignment Bits	
0	9	0	} → Values in columns: "Length of Data bits"
12	10	0	
16	11	0	
20	12	0	
24	13	0	
	14	0	
	15	2	
	16	1	
	17	0	
	18	6	
	19	5	
	20	4	
	21	3	
	22	2	
	23	1	
	24	0	

BiSS	Technical Datasheet Interface	HENGSTLER
ACURO – SSI / BiSS		

Register – mode (BiSS – Interface)

The register communication is initiated by a low signal following the first falling edge from the master on the clock line. The master keeps the clock line on low until the ACURO reacts with a falling edge on the data line and thus signaled the change over to register mode. After this has happened the master transmits the addressing data coded as a PWM signal (pulse width modulated clock signal). The individual sensors (slaves) are addressed by slave IDs which are generated automatically according to the order of the slaves in the sequential circuit. ACURO uses two slave IDs (e.g. ID "000" and "001") so that it can extend the available addressing range from 7 to 8 bits.

Revision	©Hengstler GmbH Postfach 1151 78550 Aldingen	Page
3 050517TK	☎ 07424/89-0 Fax 07424/89-500 email: info@hengstler.com Internet: www.hengstler.com	13 / 29

ACURO – SSI / BiSS

Register mode: read

Once ACURO has signaled the changeover to register mode the master transmits the start bit, the 3-bit slave ID and the 7-bit register address for the addressing sequence, followed by the WNR bit ("0") and the 6-bit CRC. Each bit is coded by the duty cycle (PWM), including the start bit. The generator polynomial for the 4-bit CRC is $0x13 = "10011"$ (see the definitions in the description of the BiSS protocol). The ACURO does not require any processing time to read the internal registers and answers immediately with the data of the addressed registers. When reading the external EEPROM registers the output is delayed until the data from the EEPROM has been made available. All 8-bit read data can also be checked for transmission errors by the 4-bit CRC $0x13$.

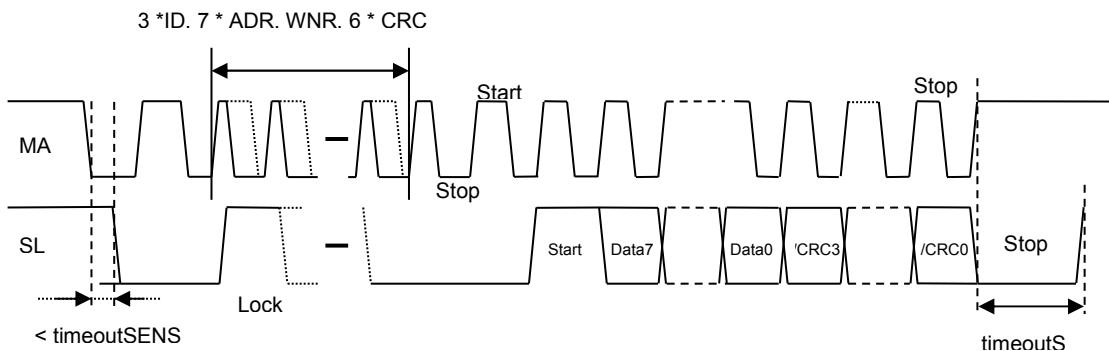

Register mode: write

When data is being written to a register, after the ACURO has confirmed the mode changeover the same addressing sequence as for read access is used (with the WNR bit at "1"). Following the second start bit the master transmits the data to be written which ACURO returns for verification, bit by bit one clock pulse later. As in the above, a 4-bit CRC have to follow the 8-bit write data which is returned by ACURO in the same manner, however not in PWM format. A transfer to the EEPROM registers is processed in the background and can be validated by a read access once transmission is over.

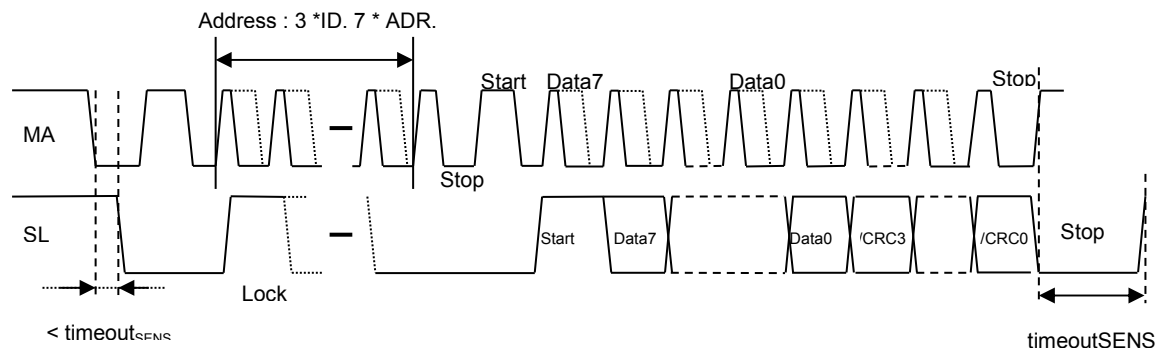

Revision	©Hengstler GmbH Postfach 1151 78550 Aldingen	Page
3 050517TK	☎ 07424/89-0 Fax 07424/89-500 email: info@hengstler.com Internet: www.hengstler.com	14 / 29

ACURO – SSI / BiSS

Timing

Timing BiSS Sensor Mode

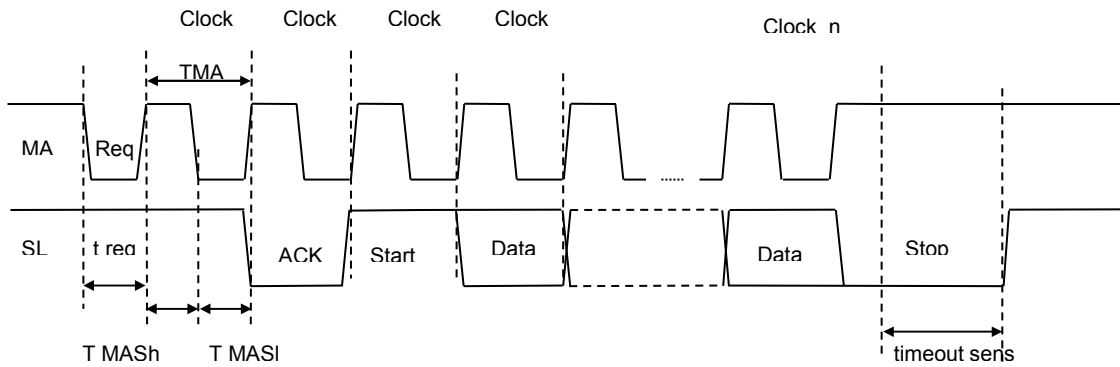

BiSS Sensor Mode						
Symbol	Parameter	Conditions	min	typ	max.	Unit
timeout sens (Ttos)*			9,9	12,4	14,9	µs
TMAS	Permissible Clock Period		100 ns		2* Ttos	
tMASH	Clock Signal Hi Level Duration		50		Ttos	ns
tMASI	Clock Signal Lo Level Duration		50		Ttos	ns
Treq	Data Request Lo Level Duration	only with SAR converter	50		Ttos	ns

* Ttos = is programmable Time

ACURO – SSI / BiSS

Timing BiSS Register Mode

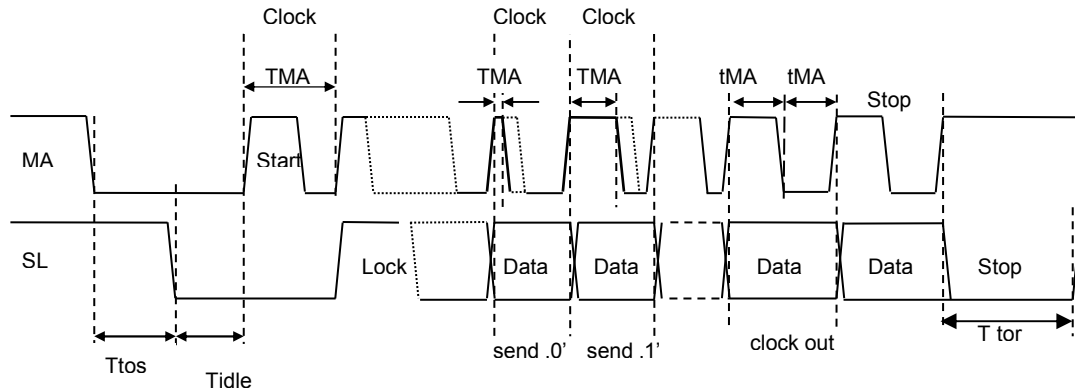

BiSS Register Mode					
Symbol	Parameter	Conditions	Min	Max.	Unit
TMAR	Permissible Clock Period	CFGTOR = 2Eh	4	52	μs
tidle	Permissible Clock Halt (idle)		0	Indefinite	
tMARh	Clock Signal Hi Level Duration	read out of register data	50 %		% TMAR
tMARI	Clock Signal Lo Level Duration			Ttor	ns
tMA0h	.Logic 0" Hi Level Duration		10	30	% TMAR
tMA1h	.Logic 1" Hi Level Duration		70	90	% TMAR

ACURO – SSI / BiSS

Example for read register 78h

Keep clock active until start bit is sent by encoder. Approx. time ~ 416 μ s

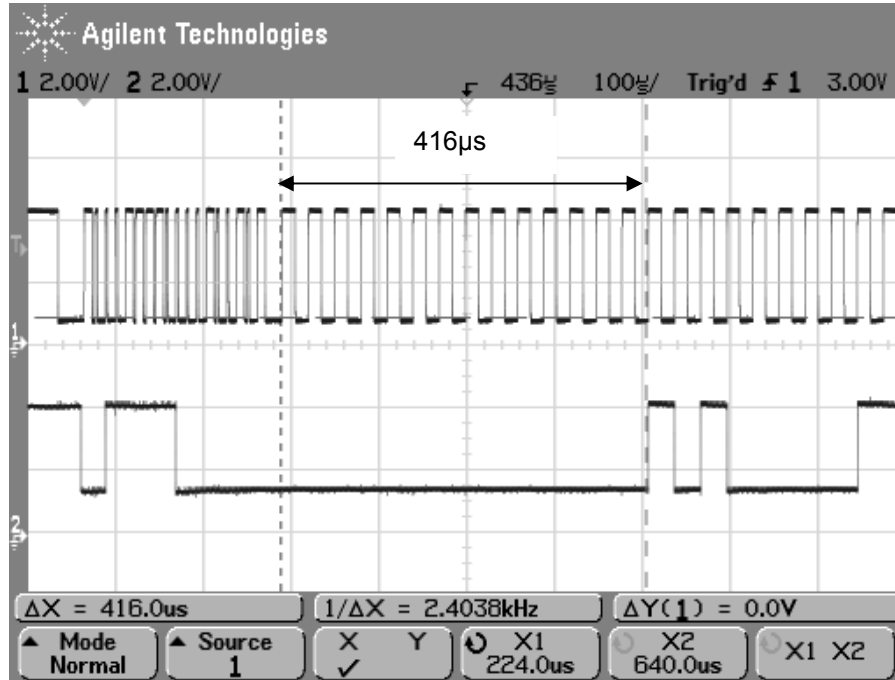

See Figure: The clock should be applied until encoder sends ACK (~ 416 μ s). This time is needed because the ASIC has to read the EEPROM internally before sending the data. There are different times for different registers because registers are mapped either directly in the ASIC or externally to an EEPROM value (takes more time).

ACURO – SSI / BiSS

Hints for PWM Signals

Code sample for PWM with port bit

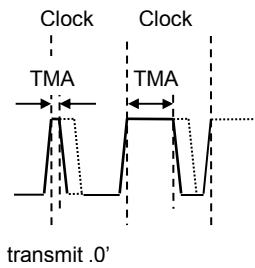

```

trans_0:                                ; 1 time high 3 time low
      set portx                          ; Output = high
      clear portx                        ; Output low
      clear portx                        ; Output low
      clear portx                        ; Output low
ret                                       ; end send '0'

trans_1:                                ; 3 time high 1 time low
      set portx                          ; Output = high
      set portx                          ; Output = high
      set portx                          ; Output = high
      clear portx                        ; Output = low
ret                                       ; end send '1'

```

x = Output Pin MA

Code sample for PWM with SPI

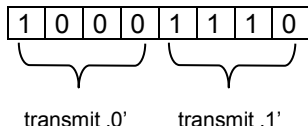

ACURO – SSI / BiSS

CRC - Generation

Depending on the configuration the length of the position data varies between 9 and 45 bits, plus an error bit and a warning bit. With a maximum length of 47 bits this data is protected by a 6-bit cyclic redundancy check value or CRC (polynomial $0x43 = "1000011"$) which directly follows the data.

A CRC "checksum" is the remainder of a binary division with no bit carry (XOR used instead of subtraction), of the message bit stream, by a predefined (short) bit stream of length n , which represent the coefficients of a polynomial. Before the division, n zeros are appended to the message stream.

Example:

The Bit stream 1000011 is equivalent to the Polynom $1x^6 + 0x^5 + 0x^4 + 0x^3 + 0x^2 + 1x^1 + 1x^0$
 $= x^6 + x^1 + 1$

Hardware

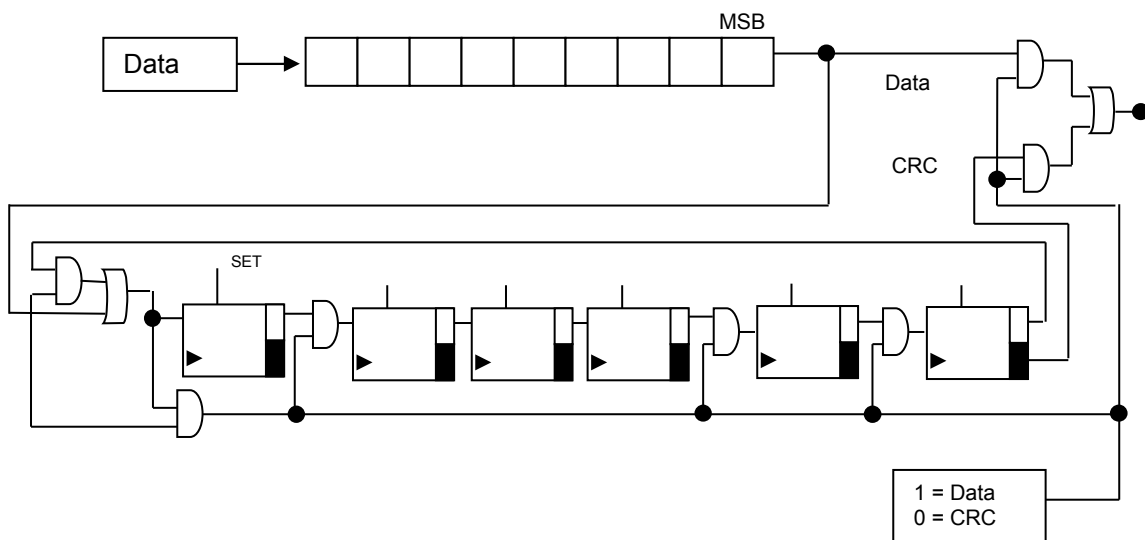

Process:

1. Shift register set to 0
2. Shift Data
3. Shift CRC

ACURO – SSI / BiSS

```

//***** function for calculating a new CRC *****/

```

```

extern byte bitString[bitZ]; // contains the data, one data bit per byte

int calcCRCnew (byte bitPolynom) // parameter = 4 or 6 bit CRC

{
    // CRC calculating for 4 bit polynom 1 0011 and 6 bit polynom 110 0011
    // XOR - function only by MSB = high of the working bytes !

    // Variable
    byte crcByte, polynom ; // resulting crc byte
    int tmpx, msb, zB, tmpy; // temporary variables

    if(bitPolynom==4) { // calculate 4 Bit CRC or 6 Bit CRC
        zB=4;
        polynom = 0x13;
    }
    else if(bitPolynom == 6){
        zB=6;
        polynom = 0x63;
    }

    crcByte = 0; // start value

    // BitString mit 4 oder 6 Nullen füllen
    // clear BitString for 4 or 6 bits

    for (tmpx = bitZ; bitZ < tmpx +bitPolynom;bitZ++) {
        bitString[bitZ] = 0;
    }
    // first fill up crc byte up to polynom length
    for (tmpx=0,tmpy = bitPolynom;tmpx <= bitPolynom; ++ tmpx, --tmpy) {
        crcByte = crcByte + (bitString[tmpx] << tmpy);
    }

    // do the shift and exor operations
    for(;;) {
        // EXOR if MSB high
        if (( crcByte >> bitPolynom) & 1 ) { // check if MSB is 1
            crcByte = ( crcByte ^ polynom ); // then do the exor
        }

        // shift
        ++ zB;
        if (zB == bitZ) // check if all bits shifted ?
            break; // finished

        else {
            crcByte = (crcByte << 1); // else continue shifting data
            if (bitPolynom == 4) // limit crc value to polynom length by masking
                crcByte = crcByte & 0x1F;

            else
                crcByte = crcByte&0x7F; // 7 Bit Maske !

            crcByte = crcByte+(bitString[zB]); // add next bit
        }
    }
    if (bitPolynom == 4) // transmit inverted crc value
        return (~crcByte)&0x0F;
    else
        return (~crcByte)&0x3F;
} // end function calcCRCneu

```

Revision	©Hengstler GmbH Postfach 1151 78550 Aldingen	Page
3 050517TK	☎ 07424/89-0 Fax 07424/89-500 email: info@hengstler.com Internet: www.hengstler.com	20 / 29

ACURO – SSI / BiSS

Sample: Set Preset

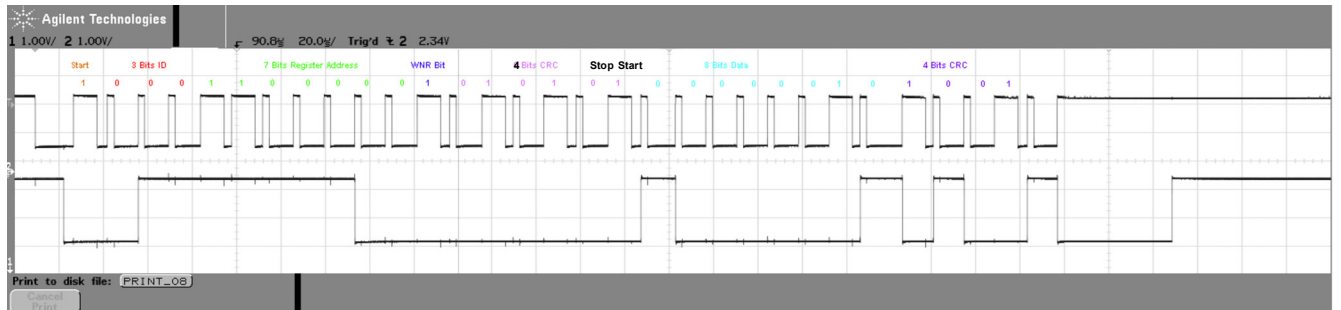

Address MAP

Address	Access Protection	Bank 0		Bank 1	Bank 2 ... 7
0x00	security	Configuration Data	128 Byte	OEM	OEM
0x5F					
0x60	Command (wr) & Status (rd) Register				
0x61	Position and Status Data				
0x69					
0x6A					
0x77	BiSS – Device ID				
0x78					
0x7F	OEM				
0x80					
0xFE	Bank select	Bank select	Bank select		
0xFF					

Bank 0: 128 Byte - OEM useable Memory

Bank 1: 256 Byte - OEM useable Memory

Bank 2...7: optional

Register Map

0x60 Command register

Preset function

When the command "Implement PRESET" (data 0x02) is written to the command register (address 0x60), the current position is written to the external configuration EEPROM as an OFFSET value. At the same time the relevant values are written to the six OFFSET registers, one after another. Sequence activity is signaled for a few microseconds after the start of the sequence with a "1" in PRES in the status register (address 0x60, bit 7). The bit switches back to "0" while the sequence is still running. The entire preset sequence ends after the sixth BUSY "1>0" change (address 0x60, bit 2: serial communication active).

0x67 Temperature Data Register (read only)

Bit 7...0 absolute temperature as 8 bit data

0x68 Error register

Bit 7 = Temperature out of defined range	default temperature range (see chapter 4.3)
Bit 6 = External failure over NERR	not necessary in BiSS mode
Bit 5 = Serial interface failure	not necessary in BiSS mode
Bit 4 = Position data not valid	not necessary in BiSS mode
Bit 3 = Failure configuration interface	not necessary in BiSS mode
Bit 2 = Position Code Error	Controls the binary code single step by step
Bit 1 = External Multiturn Error	Controls the communication between the gear PCB and singleturn PCB
Bit 0 = LED current out of control range	Pollution; Condensation, Over temperature, Ageing of LED

0x78 ..0x7F BiSS Device ID

0x78	0x41	A	Product ID	e.g. AC or AD
0x79	0x43	C		
0x7A	0x3A		58 for ACURO	

0x7B resolution

0x7C timeout

0x7D free

0x7E	0x48	H	manufacturer code
0x7F	0x45	E	Hengstler

Encoder Characteristics (Produce datas, Resolutions)

Reg. Adr.	Discription	Length	Format	1.	2.	3.	4.
Reg. 0x34	Serial No.	4 Byte	Ser. – No. BCD format	SS	SS	SS	LL
Reg. 0x38	Production- Date	4 Byte	Date BCD format	DD	MM	JJ	JJ
Reg. 0x3C	Article No.	4 Byte	Article No. BCD format	XX	XX	XX	0
Reg. 0x40	MT- Resolution	1 Byte	MT BCD format (0 / 12-Bit)	12			
Reg. 0x41	ST-Resolution	1 Byte	ST BCD format (9...22-Bit)	19			
Reg. 0x42	Alignment Bits	1 Byte	BCD format (0...11-Bit)	5			
Reg. 0x43	SinCos-Periods	2 Byte	SinCos BCD format	20	48		

Example Data Output BiSS Protocol

Resolution AD36 1219

Reg. 0x40	MT-Resolution	1 Byte	MT BCD	12			
Reg. 0x41	ST- Resolution	1 Byte	ST BCD	19			
Reg. 0x42	Alignment Bits	1 Byte	BCD	5			

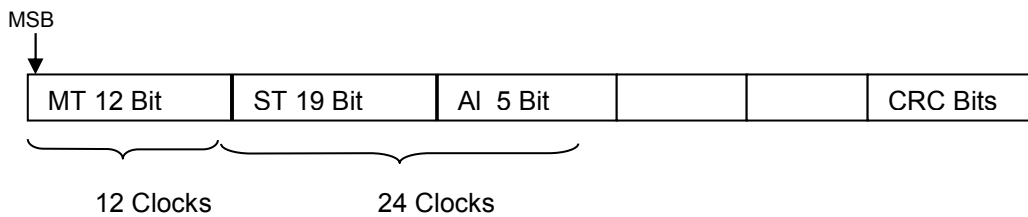

Resolution AD36 0019

Reg. 0x40	MT- Resolution	1 Byte	MT BCD	0
Reg. 0x41	ST- Resolution	1 Byte	ST BCD	19
Reg. 0x42	Alignment Bits	1 Byte	BCD	5

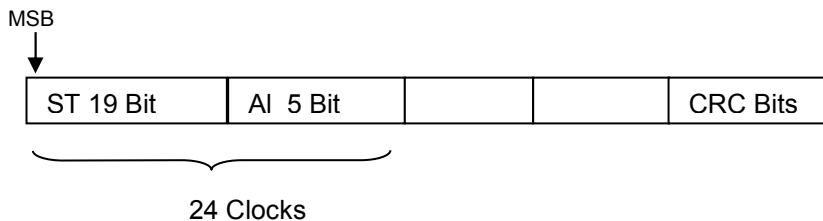

Resolution AD36 1214

Reg. 0x40	MT- Resolution	1 Byte	MT BCD	12
Reg. 0x41	ST- Resolution	1 Byte	ST BCD	14
Reg. 0x42	Alignment Bits	1 Byte	BCD	0

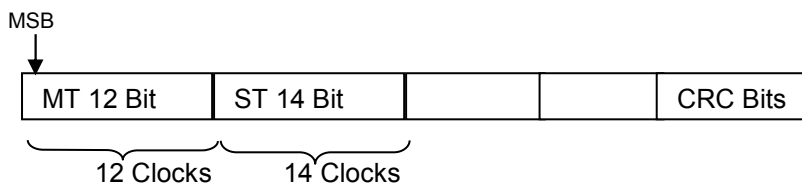

ACURO – SSI / BiSS

Recommended Interface

SSI Standard with Incremental signals

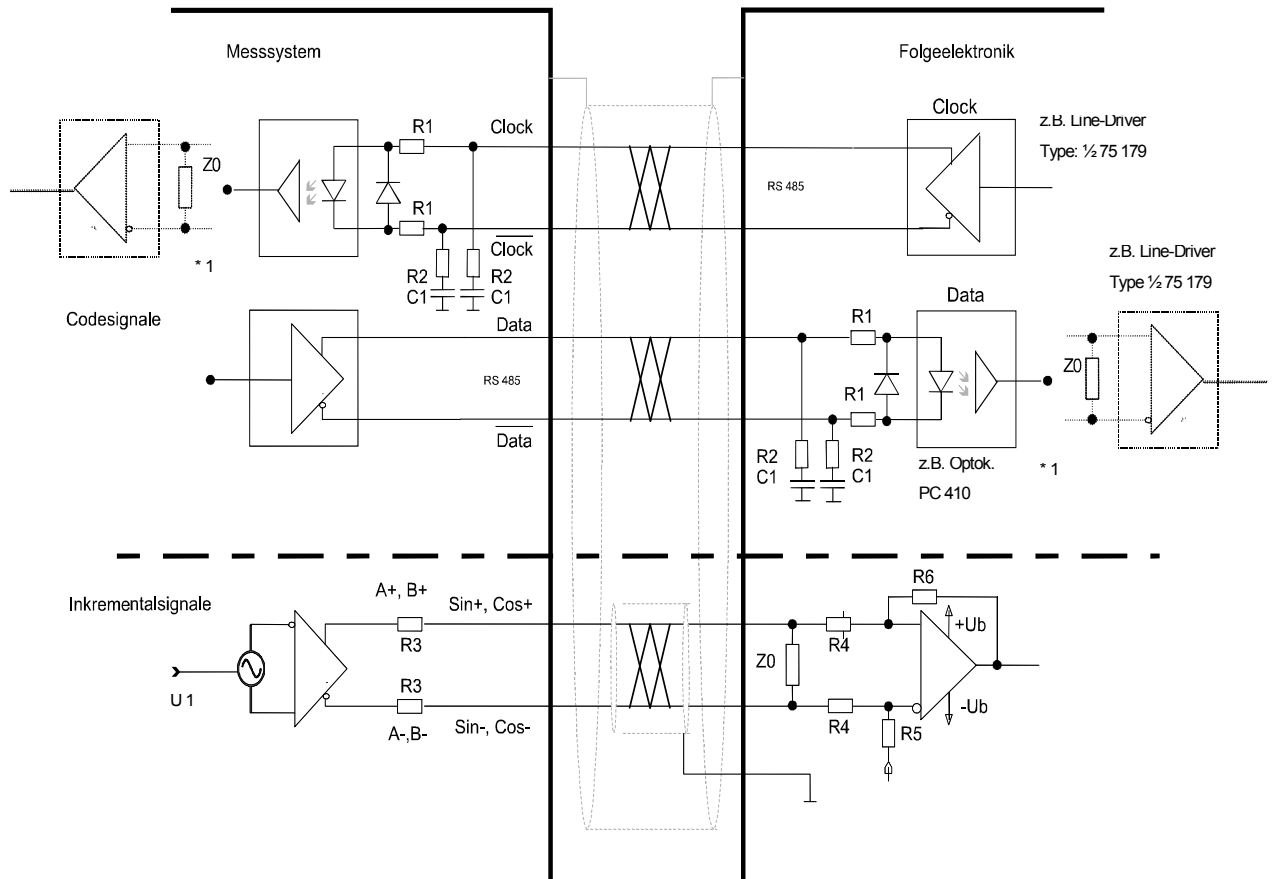

Dimensioning:

$R1 = 91 \Omega$, $R2 = 100 \Omega$, $R3 = 10 \Omega$, $R4 = 10k\Omega$, $R5 = R4 \cdot \text{desired adjustment}$, $Z0 = 120 \Omega$

$C1 = 1nF$

$U_1 = 2,5 V \pm 0,5V$ (referred to operating voltage)

*1) Alternative population for high transmission rates (> 2MHz) and simultaneous operation of several encoders (i.e. common clock, separate data lines).

Revision	©Hengstler GmbH Postfach 1151 78550 Aldingen	Page
3 050517TK	☎ 07424/89-0 Fax 07424/89-500 email: info@hengstler.com Internet: www.hengstler.com	25 / 29

ACURO – SSI / BiSS**BiSS Standard Encoder**

Supply 10...30 Volt

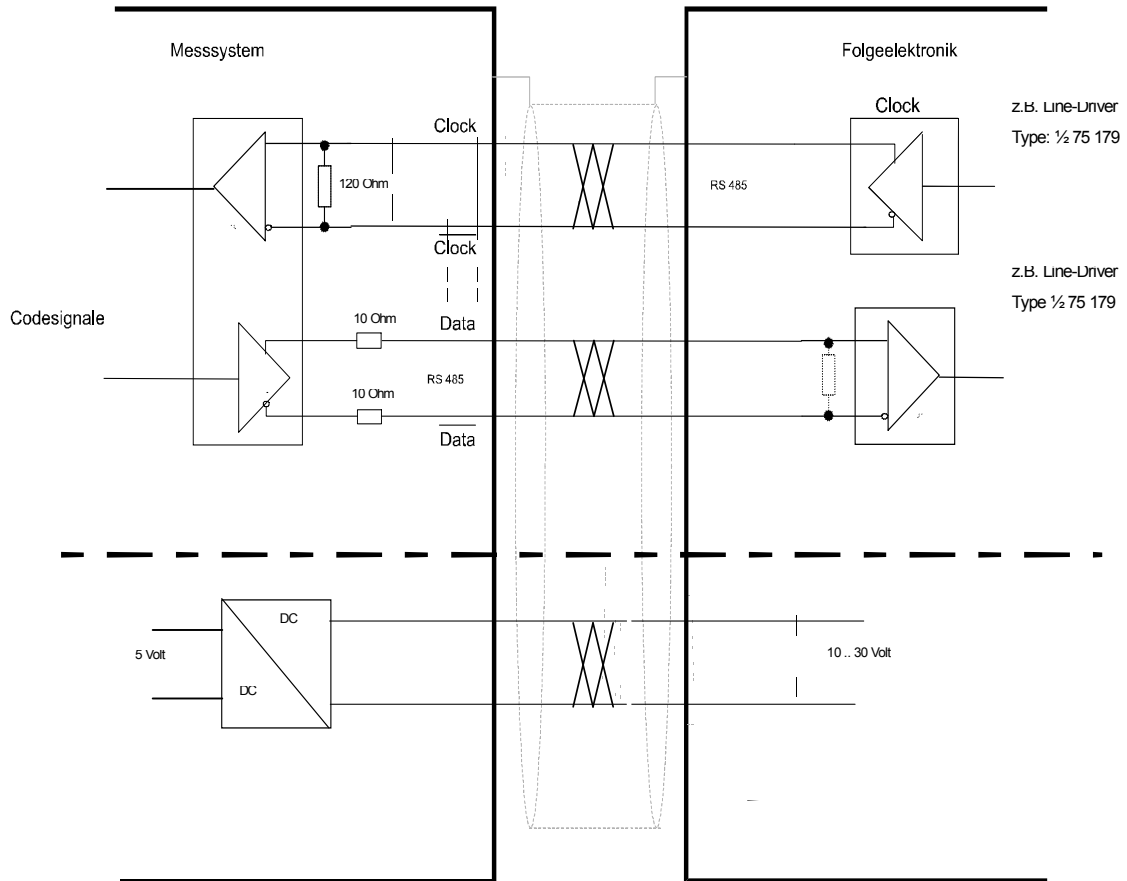

ACURO – SSI / BiSS

Electrical behaviour at power up in BiSS Mode

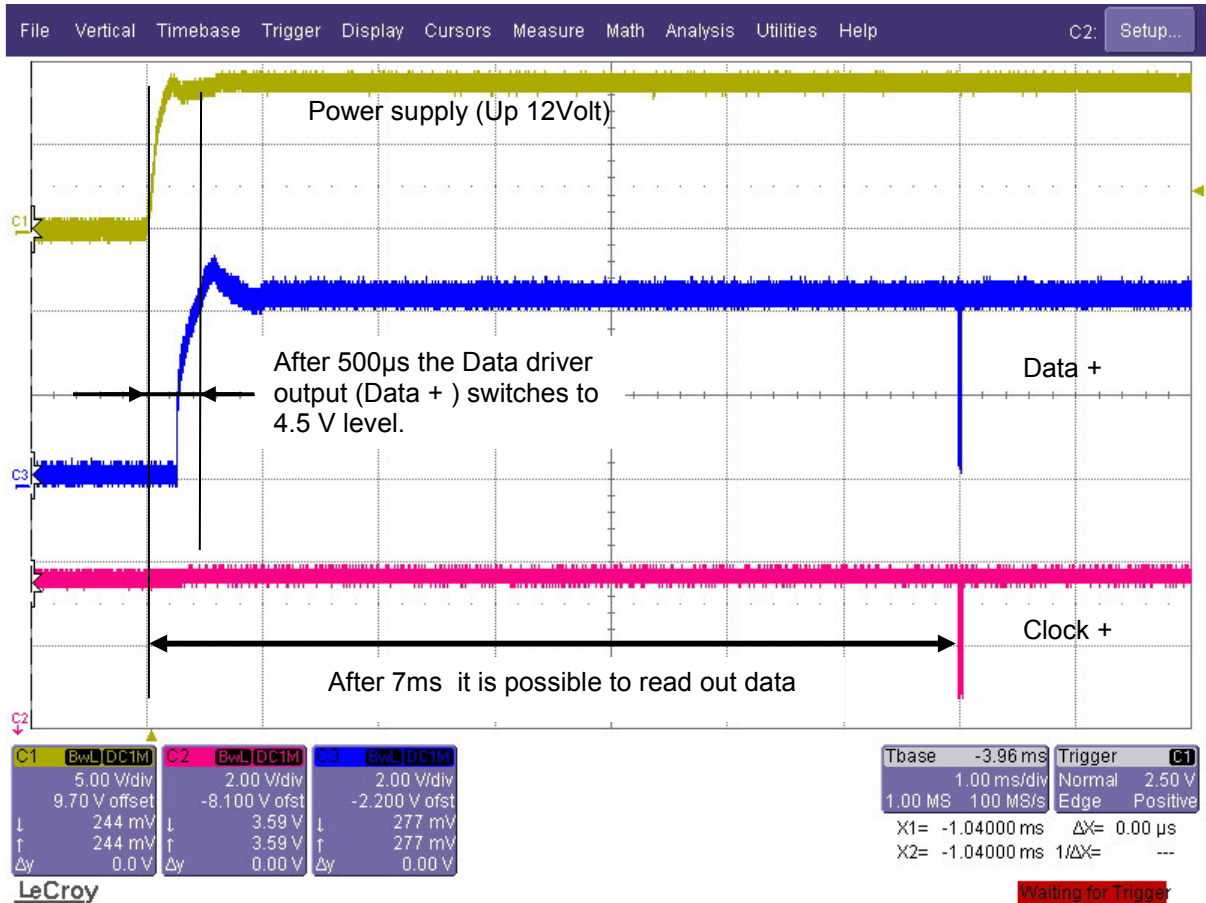

ACURO – SSI / BiSS**Cable length and clock frequency****SSI interface**

For **SSI** the maximum data transmission rate depends on the length of the cable. The clock frequency is variable between 100 kHz and 1.5 MHz. That means a long cable and a high clock frequency that can disturb the data signal due to propagation delay of the signals over copper wires. So it is necessary to reduce the clock frequency or the cable length.

BiSS interface

Due to the built in propagation delay compensation of the BiSS interface (ACURO and BiSS - Master) the clock frequency can be up to 10 MHz and simultaneously the cable length up to a maximum of 100 m. The maximum clock frequency is mainly determined by the cable and connecting elements that are used. For 10 MHz the cable should be compliant with CAT 5.

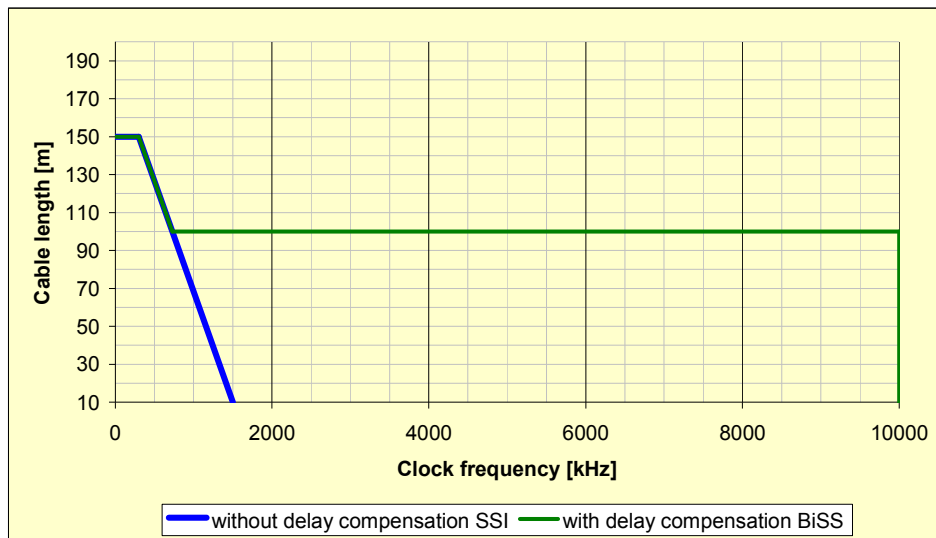

Recommended cable length without delay compensation (SSI) and with delay compensation (BiSS). The cable must be twisted pair and shielded.

BiSS	Technical Datasheet Interface	HENGSTLER
ACURO – SSI / BiSS		

© by HENGSTLER

HENGSTLER claims copyright protection for this documentation.

This documentation must not be modified, amended, copied or given to third parties without prior written approval by HENGSTLER.

ACURO® is a registered trademark of HENGSTLER

We reserve the right to make technical modifications and improvements that provide technical progress to our products.

HENGSTLER

HENGSTLER GmbH
 Uhlandstr. 49
 78554 Aldingen / Germany
 Tel. +49 (0) 7424-89 0
 Fax +49 (0) 7424-89 500
 E-Mail: info@hengstler.com
www.hengstler.com

Revision	©Hengstler GmbH Postfach 1151 78550 Aldingen	Page
3 050517TK	☎ 07424/89-0 Fax 07424/89-500 email: info@hengstler.com Internet: www.hengstler.com	29 / 29